

ABB Component Drives

ACS55, 0.25 to 3 Hp

Technical Catalog



ABB Component Drive



What is the ACS55 customer value?

- Reduces panel size
- Reduces commissioning, installation and energy costs
- Replaces contactors and starters

The ABB ACS55 Component Drive continues in the tradition of ABB AC Drives being simple to buy, install, configure and use, saving considerable time. The ACS55 can easily be integrated into existing or smaller panels, replacing contactors and motor starters due to its compact size as well as new installations or wherever energy savings of small AC induction motors is desired.

Where can it be used?

The ABB ACS55 Component Drive can be used in a wide range of industries. Typical applications include pumps and fans as well as constant torque applications such as material handling. The ABB ACS55 Component Drive is ideal for those situations where a low cost, easy to install and easy to operate product is needed. Additional applications include:

- Heat Exchangers
- Packaging Machines
- X-ray Screening Systems
- Exercise Training & SPA Equipment
- Ovens
- Powered Roof-Ventilators
- Food & Beverage Machines

ABB ACS55 Component Drive Promises

- Easy and descriptive interface
- Compact size and slim
- DIN rail mounting
- Quiet motor operation

Highlights

- Power range 0.25 to 3 Hp
- Protected Chassis (IP 20)
- Silent Motor
- Optimized switching frequency up to 16kHz
- Suitable for domestic environment
- Fast and safe drive configuration with DriveConfig kit
- Ideal for DIN-rail mounting
- RoHS
- Coated boards

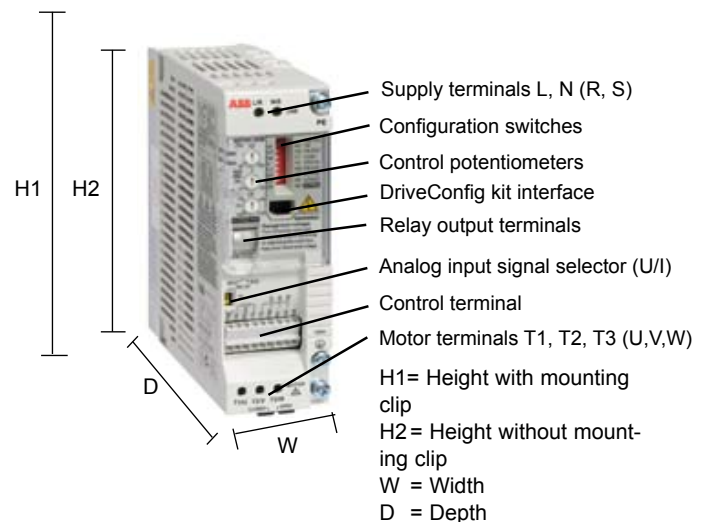

What are the ACS55's main features and benefits supporting customer value?

Feature	Note	Benefit
Descriptive Interface	All inverter parameter settings are made with DIP switches and potentiometers	Faster set-up Easier configuration Easier set-up for new users
Compact size and thin shape	up to 0.5 Hp 1.77" width, 1 Hp 2.66" width	Less space required for installation
DriveConfig kit	New drive configuration tool for volume manufacturing	Fast and safe configuration of un-powered drives
Removable mounting clip	Removable clip allows DIN-rail and wall mounting from back and side of the unit	Flexible and easy mounting
Automatic switching frequency	Increases switching frequency automatically, when drive temperature is decreased	Provides lowest possible noise without derating of the drive
EMC	1st Environment built-in EMC filter unit is available	Low EMC emissions

Ratings, Types and Voltages



Type Code	Frame Size	P _N Hp	Output Current		Input Current A	Dimensions inches				Weight lbs
			Nominal I _{2N} A	Maximum A		H1	H2	W	D	
1-phase supply voltage 110 to 120V, +10/-15%, 3-phase output 200 to 240V										
ACS55-01N-01A4-1	A	0.25	1.4	2.1	6.4	6.69	5.77	1.77	5.04	1.5
ACS55-01N-02A2-1	A	0.5	2.2	3.3	9.5	6.69	5.77	1.77	5.04	1.5
1-phase supply voltage 200 to 240V, +10/-15%, 3-phase output 200 to 240V										
ACS55-01N-01A4-2	A	0.25	1.4	2.1	4.4	6.69	5.77	1.77	5.04	1.5
ACS55-01N-02A2-2	A	0.5	2.2	3.3	6.9	6.69	5.77	1.77	5.04	1.5
ACS55-01N-04A3-2	B	1.0	4.3	6.5	10.8	6.69	5.77	2.66	5.04	2.4
ACS55-01N-07A6-2	C	2.0	7.6	11.4	18.2	7.6	6.7	2.8	6.3	2.4
ACS55-01N-09A8-2	C	3.0	9.8	14.7	22	7.6	6.7	2.8	6.3	2.4

Type Code	Frame Size	P _N Hp	Output Current		Input Current A	Dimensions inches				Weight lbs
			Nominal I _{2N} A	Maximum A		H1	H2	W	D	
1-phase supply voltage 110 to 120V, 3-phase output 200 to 240V (Built-in EMC filter)										
ACS55-01E-01A4-1	A	0.25	1.4	2.1	6.4	6.7	5.7	1.77	5.0	1.4
ACS55-01E-02A2-1	A	0.5	2.2	3.3	9.5	6.7	5.7	1.77	5.0	1.5
1-phase supply voltage 200 to 240V, 3-phase output 200 to 240V (Built-in EMC filter)										
ACS55-01E-01A4-2	A	0.25	1.4	2.1	4.4	6.7	5.7	1.77	5.0	1.4
ACS55-01E-02A2-2	A	0.5	2.2	3.3	6.9	6.7	5.7	1.77	5.0	1.5
ACS55-01E-04A3-2	B	1.0	4.3	6.5	10.8	6.7	5.7	2.6	5.0	1.5
ACS55-01E-07A6-2	D	2.0	7.6	11.4	18.2	8.9	8.0	2.7	6.2	2.4
ACS55-01E-09A8-2	D	3.0	9.8	14.7	22	8.9	8.0	2.7	6.2	2.4

P_N = Nominal Power
I_{2N} = Nominal Current

Options



RFDT-01 or RFDT-02 DriveConfig Kit

The DriveConfig kit is a PC tool for volume configuration and control of ACS55 drives. The kit enables parameter setting and software updating without the need for a power connection. The drives can even remain in their delivery boxes during configuration. The DriveConfig kit features on-line drive control and monitoring of up to four signals simultaneously. Together with ACS55 drives, the DriveConfig kit brings additional value to processes by saving time and ensuring safety.

DriveConfig kit includes:

- Hardware and cables
- PC software
- User's manual in English (hardcopy and PDF)
- Battery charger
- Serial port (RFDT-01) / USB adapter (RFDT-02)

DriveConfig kit requirements:

- PC with Microsoft Windows 2000/XP operating system
- Free serial or USB port from the PC



Potentiometer

The ACS50-POT potentiometer is an option for ACS55 drives. Two switches are included in addition to the potentiometer for drive control; start / stop and forward / reverse. The ACS50-POT potentiometer does not require any external power source

Type Code

ACS50-POT

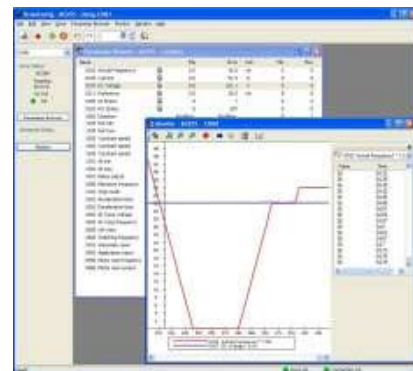

Technical Specification



Mains Connection

Power range	0.25 to 3.0Hp (0.18 to 2.2kW)
Input Voltage	1-phase, 110 to 120V and 200 to 240V, +10/-15%
Frequency	48 to 63Hz

Motor Connection

Output Voltage	3-phase, from 0 to U_{SUPPLY} (for 100/115V from 0 to 230V)
Frequency	0 to 120/130Hz
Overload Capacity	150% (60 s)
Switching Frequency	5kHz, adjustable up to 16kHz with automatic switching frequency reduction
Acceleration Time	0.1 to 30 s
Deceleration Time	0.1 to 30 s

Environmental Limits

Ambient Temperature	-4°F (-20°C) to 104°F (40°C) No Frost Allowed 122°F (50°C) with derating to 85% nominal output current
Altitude	0 to 3280 ft (1000 m) with derating of 1% per 320 ft (100 m) over 3280 ft (1000 m) to 6560 ft (2000 m)
Relative Humidity	Less than 95% (without condensation)
Protection Class	IP20, Protected Chassis
Contamination Levels	No conductive dust allowed, corrosive liquids or gasses (IEC60721-3-3) Chemical gases: Class 3C2 Solid particles: Class 3S2
Sinusoidal Vibration	Frequency range: 5 - 150 Hz Constant Peak Acceleration: 1g ISTA 2A

Control Connections

One analog input	
Voltage Signal	0 (2) to 10V, 200kΩ single-ended
Current Signal	0 (4) to 20 mA, 100Ω single-ended
Potentiometer reference value	10V ±2% max 10mA, 1kΩ ≤ R ≤ 10kΩ
Response Time	≤ 60 ms
Resolution	0.1%
Accuracy	±2%
Three Digital Inputs	12VDC to 24VDC
Auxiliary Power Supply	12VDC max 30mA
Input Impedance	1.5kΩ
Response Time	≤ 9 ms
One Relay Output	
Switching Voltage	12 to 250VAC or max 30VDC / 0.5A
Maximum Continuous Current	2A

Product Compliance

Low Voltage Directive 73/23/EEC with supplements
EMC Directive 89/336/EEC with supplements
Quality assurance system ISO 9001 and Environmental system ISO 140001
CE, UL, cUL, C-Tick, and GOST-R approvals

EMC standards in general

EN 61800-3/A11 (2000), product standard	EN61800-3 (2004), product standard	EN 55011, product family standard for industrial, scientific and medical (ISM) equipment
1 st environment, unrestricted distribution	Category C1	Group 1 Class B
1 st environment, restricted distribution	Category C2	Group 1 Class A
2 nd environment, unrestricted distribution	Category C3	Group 2 Class A
2 nd environment, restricted distribution	Category C4	Not applicable

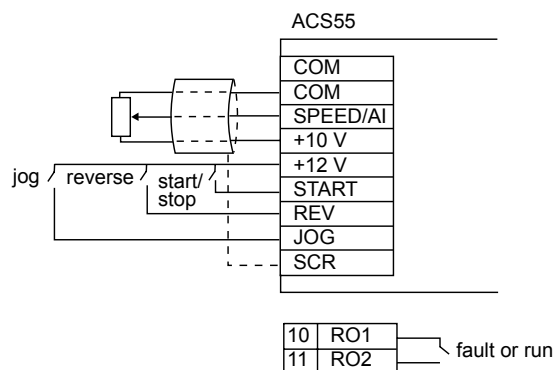

Notes:



Notes:





ABB Inc
Low Voltage Drives
16250 W. Glendale Drive
New Berlin, WI 53151
USA
Telephone (800) 752-0696
Fax (262) 785-0397
Internet <http://www.abb.us/drives>

ABB Inc
Drives and LVC Canada
3299 J.B. Deschamps Blvd
Lachine, Quebec
H8T 3E4
Telephone (800) 215-3066
Fax (514) 420-3137
Internet <http://www.abb.com/motors&drives>